



Mod. **VV1**

First Class Wind Speed Sensor

<u>FIRST CLASS</u>		
<u>Class A</u>	<u>Class B</u>	<u>Class S</u>
<u>1.96</u>	<u>3.05</u>	<u>2.42</u>

Highlighted specs

- High precision <0,1m/s
- High linearity $R > 0,99998$
- Calibrations: MeasNet and ISO17025
- Classification IEC 61400-12-1 and EN 15518-3:2011 compliant
- WMO standards compliant
- Low power consumption heated version (5W@12Vdc)
- Rotor with high speed and long life ball bearing (MIL-L-6085 C)
- According to **CE** norms
- IP68 fast connection

First Class anemometer with **very high precision**, manufactured to meet the strictest standards for measuring the wind such as the **IEC61400-12** for eolic monitoring. They are high performance instruments, **certificated MeasNet**, made in metal with high quality materials to ensure reliability and durability, allowing to maintain over time the initial features of sensitivity and precision. They are **compliant with WMO norms** (World Meteorological Organization) and to **EN 15518-3:2011 norm**. Available with different signal outputs, normalized voltage or current $0 \div 2Vdc$, $4 \div 20mA$ or **RS485/Modbus**, and a **heated version with low consumption (<5W @ 12Vdc)**.

Typical measurement range	0.28 ÷ 50 m/s (0...150Hz) up to 100m/s (freq. output)
Resolution	0.05m/s wind run
Average accuracy	<0.1 m/s (0.4 ÷ 30m/s); $\leq \pm 1\%$ v.m. (>30 m/s)
Typical linearity	$r > 0.99998$ standard error 0.02m/s; (m/s) = (Hz x 0.30) + 0.3
Threshold	stopping 0.1 m/s; starting <0.3 m/s
Type of transducer	3 cups (Robinson reel) with magnetic transducer
Signal output	$0 \div 2Vdc$, $4 \div 20mA$; $0 \div 150Hz$ (50 Ohm on 20mA max), Digital RS485/ModBus
Working conditions	$-10 \div +70^\circ C$ - $0 \div 100\%$ Humidity; blasts $0 \div 100$ m/s ($-40 \div +70^\circ C$ heated version)
Protections	Polarity reverse and transient
Made of	Anodized aluminium and stainless steel
Power supply and consumption	$10 \div 28Vdc$ <0,1W; 5W@12Vdc heated version
Weight	<390g

Size and connections

Pin	VV1-N VV1R-N	VV1-A VV1R-A	VV1-B VV1R-B	VV1-C VV1R-C
1				
2		Out +	Out +	RS485 A
3	Out o.c. (Hz)	Out -	Out -	RS485 B
4	Gnd	Gnd	Gnd	Gnd
5	Vdc(10÷16V)	Vdc(10÷28V)	Vdc(10÷28V)	Vdc(10÷28V)
6*	+12V Heater	+12V Heater	+12V Heater	+12V Heater
7*	Gnd Heater	Gnd Heater	Gnd Heater	Gnd Heater

*Heated version only

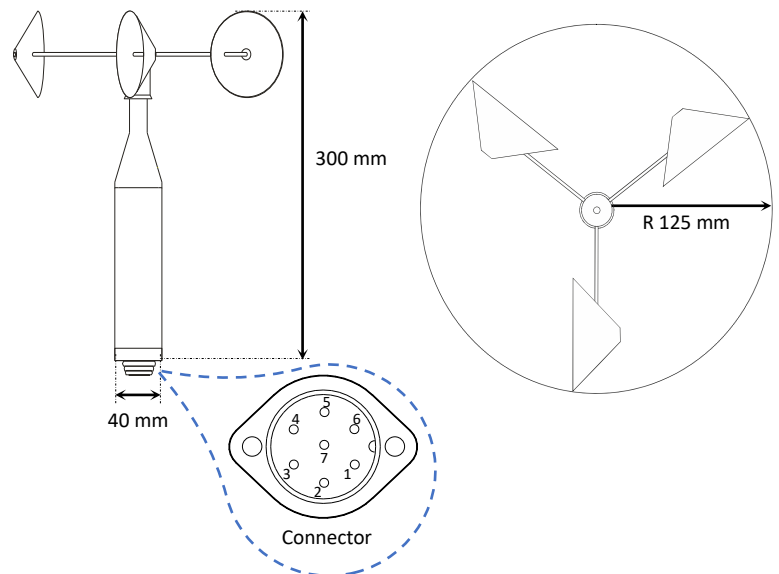

Order code

Sensor	First Class Wind Sensor First Class Heated Wind Sensor	VV1 VV1R			
Output	$0 \div 2Vdc$ $4 \div 20mA$ RS485 / Modbus Frequency $0 \div 150Hz$ (50 Ohm) or $0 \div 300Hz$		A B C N		
Accessories	CS05 – Cable 5m sensor-datalogger CS10 – Cable 10m sensor-datalogger CSxx – Cable xx* m length, sensor-datalogger – to be specified at order			05 10 xx	
	SSU - Support L = 700-750mm for fixing sensor $\varnothing 40mm$ and clamping jaw to poles \varnothing max 60mm				SSU

*specify the length for no standard measures

example of order code

VV1 N 10 SSU